



## C Series®

### High Performance Commercial Bronze Pumps



***For commercial and high-end residential swimming pools and other water applications. Available in flows to 740 GPM, and from 5 to 20 HP.***

The C Series is a heavy-duty commercial pump specifically designed for large pools, fountains and water attractions that demand high flow rates and continuous operation. With bronze construction and a stainless steel strainer basket, the C Series is perfect for the toughest indoor or outdoor projects. This pump's lasting efficiency, quiet operation, easy maintenance, and durability has set the standard for medium- and high-head performance in the pool industry for many years.

Available with and without a hair and lint strainer.

#### Standard Features

- All bronze construction for strength and durability.
- Close coupled for quiet, stable flow.
- Heavy-gauge stainless steel strainer basket, with open area five times the area of the suction port.
- 6 inch suction and 4 inch discharge for maximum efficiency with strainer.
- Closed impeller for longer motor bearing life.
- Heat-resistant seal for operation up to 150°.
- Available in single- and three-phase 50 and 60 Hz models.
- 200/208 and 575 volt models available on request.
- One-year limited warranty. See warranty for details.

# C Series<sup>®</sup> High Performance Commercial Bronze Pumps

**Pump Performance Curve  
CH/CHK Series Pump**

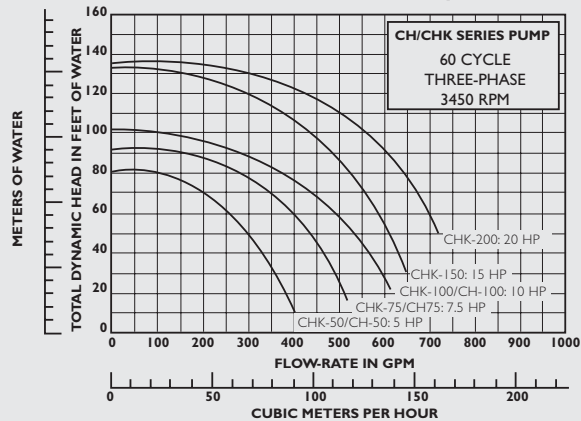

**Pump Performance Curve  
CM/CMK Series Pump**

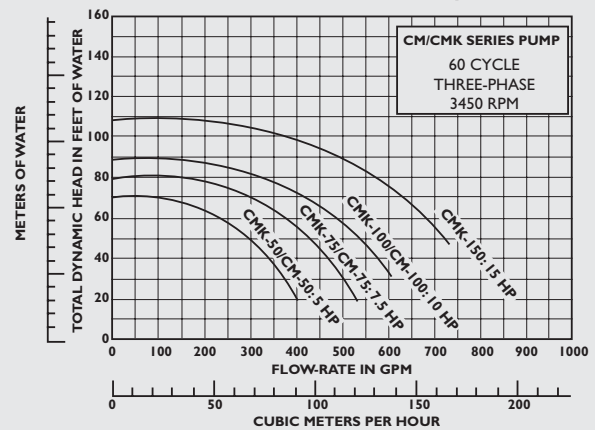

## MATERIALS AND DESIGN

### Pump Body

#### Volute type, back pull-out design

- **Port Size**  
6" – ANSI<sup>®</sup> 125 lb. bolted flange suction port on strainer.  
5" – ANSI<sup>®</sup> 125 lb. bolted flange suction port less strainer.  
4" – ANSI<sup>®</sup> 125 lb. bolted flange discharge port.
- **Material**  
Volute & Motor Adapter  
Bronze CA 84400.
- **Impeller**  
Bronze CA 83600.
- **Base**  
Enamel Coated Cast Iron Foot CL30.
- **Corrosion Prevention**  
All-bronze pump with stainless steel basket for maximum corrosion prevention.

### Hair and Lint Strainer

- **Material**  
Strainer pot – Bronze CA 84400.  
Strainer – Stainless Steel.
- **Size**  
6" ANSI<sup>®</sup> 125 lb. bolted flange suction ports.

### Pump Maximum Limits

- **Liquid Temperature:** 104°.
- **Ambient Air Temperature:** 104°.

### Motor

#### TY Frame Motor

- **Frame size**  
NEMA<sup>®</sup> flange. 230/460V are open drip-proof design.
- **Shaft**  
303 Stainless steel construction.
- **Design**  
5 to 20 HP, 3500 RPM, JM open drip-proof, continuous duty, three-phase and single-phase (5, 7 ½, and 10 HP only).
- **Bearings**  
Lubricated double sealed ball bearings
- **Thermal Overload Protection**  
All models require external thermal overload protector.

### Electrical

- **Power Supply Required**  
Three-phase pumps are 208/220-440 and 200/208.  
5, 7 ½, and 10 HP Single-phase models are available in 230V, 60 Hz only.

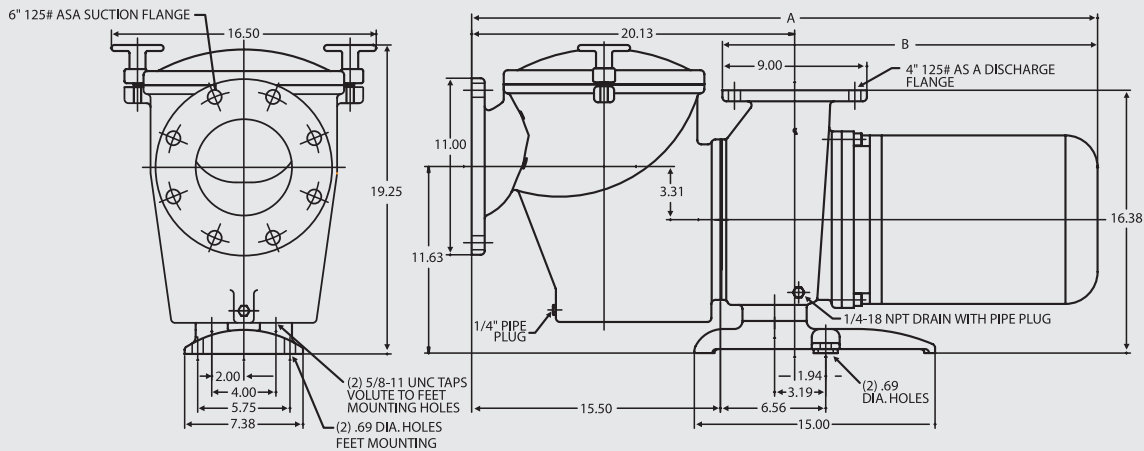

PUMP DIMENSIONS			
THREE-PHASE AMPS @ 220/440 & 380/415 V			
HP	AMPS	A	B
5	14	34.88	19.50
7.5	20	35.88	20.50
10	26	36.88	22.50
15	38	37.38	22.00
20	46	37.88	23.50

PUMP DIMENSIONS			
SINGLE-PHASE AMPS @ 230 VOLTS			
HP	AMPS	A	B
5	26	35.50	20.50
7.5	37	35.88	20.50

PUMP DIMENSIONS			
SINGLE-PHASE AMPS @ 200 VOLTS			
HP	AMPS	A	B
5	29	35.50	20.50
7.5	39.6	35.88	20.50

NOTES:  
 1. BOTH "A" AND "B" DIMENSIONS ARE APPROXIMATE IT DEPENDS ON MOTOR MANUFACTURER.  
 2. ALL DIMENSIONS ARE IN INCHES AND MAY VARY ± .25.

## C Series Models with Hair and Lint Strainer

CHK/CMK Three-Phase 200/208V 60 Hz <sup>3</sup>					
Product	Model	Voltage	Amps	HP	Carton Wt. (lbs.)
347940	CMK-50	200/208V	16.1	5	336
347941	CHK-50	200/208V	16.1	5	336
347942	CMK-75	200/208V	22.3	7.5	346
347943	CHK-75	200/208V	22.3	7.5	349
347944	CMK-100	200/208V	28.7	10	374
347945	CHK-100	200/208V	28.7	10	376
347946	CMK-150	200/208V	43.7	15	396
347947	CHK-150	200/208V	43.7	15	398
347948	CHK-200	200/208V	54	20	474
CHK/CMK Three-Phase 220/440V 60 Hz					
011657	CHK-50	220/440V	13/6.5	5	336
011652	CMK-50	220/440V	13/6.5	5	336
011658	CHK-75	220/440V	18/4.92	7.5	349
011653	CMK-75	220/440V	18/4.92	7.5	346
011659	CHK-100	220/440V	25.3/12.7	10	376
011654	CMK-100	220/440V	25.3/12.7	10	374
011660	CHK-150	220/440V	37.6/18.8	15	398
011655	CMK-150	220/440V	37.6/18.8	15	396
011661	CHK-200	220/440V	49/24.6	20	474
CH/CM Single-Phase 200/208V only 60 Hz					
347938	CM-50	200/208V	29.0	5	352
347939	CH-50	200/208V	29.0	5	352
348001	CM-75 <sup>1</sup>	200/208V	39.6	7.5	375
348005	CH-75 <sup>1</sup>	200/208V	39.6	7.5	375
CH/CM Single-Phase 230V only 60 Hz <sup>2</sup>					
011651	CM-50	230V Only	24.0	5	352
011656	CH-50	230V Only	24.0	5	352
347916	CH-75	230V Only	37.0	7.5	375
347917	CM-75	230V Only	37.0	7.5	375
347963	CH-100	230V Only	51.0	10	376
347964	CM-100	230V Only	51.0	10	376

<sup>1</sup>Not NSF listed.

<sup>2</sup>208V not available.

<sup>3</sup>Full load amps shown.

# C Series®

## High Performance Commercial Bronze Pumps



### ENGINEERING SPECIFICATIONS

#### C Series Pump

- Recirculation pump shall be Pentair C Series Model No. \_\_\_\_\_ centrifugal pump, \_\_\_\_\_ phase, 60 Hz.

#### Installation

- Install pump in a cool, dry, well-vented location away from pool heaters, and chemical storage.
- Pump should be firmly mounted with pipe supported to prevent vibration and undue operational noise.
- Allow 12" minimum clearance behind motor for servicing.
- Motor overheating may be caused by a voltage drop or excessive voltage. Be sure that wire size and voltage input is properly regulated.

#### Specifications

- The recirculation pump shall be a centrifugal design with a hair and lint strainer as shown in the plans.
- The pump body and attached hair and lint strainer shall be constructed of non-corrosive Bronze materials, and close-coupled to an electric motor by means of an adaptor of the same material. The pump body shall have a single suction port with a 6" ANSI® 125 bolt flange to the hair and lint strainer. A centerline discharge port of 4" ANSI® 125 bolt flange and a winterizing drain port of ¼" NPT shall be a part of the design.
- The pump shall be a back pullout design to allow servicing without disturbing piping. The impeller shall be of the closed type and Bronze materials, non-overloading at any point on the performance curve. The mechanical shaft seal shall be constructed of ceramic and carbon seal faces, with stainless steel, brass and Buna N materials

in the spring bellows portion. The impeller shall be secured to the motor shaft by means of a stainless steel key and locking screw into the end of the motor shaft. The pump shall be capable of operating at up to 50 psi, 104°F continuous water temperature.

- The electric motor coupled to the pump shall be of the NEMA® series JM construction with stainless steel shaft inside a removable shaft sleeve of 300 series stainless steel. The motor shall be of an open, drip-proof design (unless otherwise specified) with double shielded, single row, deep groove ball bearings. Motors shall be continuous duty rated at 40°C (or better) ambient and be suitable for outdoor installation.
- The pump motor shall be a \_\_\_\_\_ HP, \_\_\_\_\_ phase, 60 Hz, 3450 RPM for service on a \_\_\_\_\_ volt electric supply. The pump shall be rated for \_\_\_\_\_ GPM at \_\_\_\_\_ TDH. The pump shall be tested and certified by a nationally recognized testing laboratory to conform to National Sanitation Foundation Standard 50.

#### Hair and Lint Strainer

- The pump strainer shall consist of a Bronze body, Bronze cover with O-ring seal, and threaded locking bolts, and a strainer basket of stainless steel.
- The strainer body shall be 6" ANSI® 150 bolt flanged suction ports. The strainer body shall have a removable drain plug for winterizing.
- The strainer basket shall be securely positioned below the suction inlet of the trap, with access for inspection and cleaning through a removable trap body lid. The trap body lid shall be secured by means of a 2 hand nut assemblies. The strainer basket shall have a perforation, which in total open area is 5 times the area of the suction port.



1620 Hawkins Avenue

Sanford, NC 27330

Phone: 800-831-7133 Fax: 800-284-4151

[www.pentairpool.com](http://www.pentairpool.com)